

MAGLITE®

THE PROFESSIONAL FLASHLIGHT®

Rechargeable System (NiCad)

Oplaadbaar systeem (NiCad)

Système Rechargeable (NiCad)

Aufladbar (NiCad)

Sistema Recargable (NiCad)



*Owner's Manual • Gebruiksaanwijzing • Guide d'Utilisation
Handbuch • Manual del Proprietario*

For Your Safety Please Read

WARNING:

Always read and understand all of the warnings and safety instructions contained in this manual before attempting to use the Mag-Lite® Rechargeable Flashlight System™ to help avoid potential hazards that could result in bodily injury or property damage.

Always keep this manual conveniently available for future reference, as it contains important information that will help effect the safe operation and maintenance of this instrument.

Any battery may leak harmful chemicals which may damage skin, clothing, or the inside of the flashlight. **TO AVOID RISK OF INJURY, DO NOT LET ANY MATERIAL LEAKED FROM A BATTERY COME IN CONTACT WITH EYES OR SKIN.** Any battery may rupture or explode if put in a fire or otherwise exposed to excessive heat. **TO AVOID RISK OF INJURY, DO NOT EXPOSE BATTERIES TO EXCESSIVE HEAT.** To reduce the risk of personal injury or harm to your flashlight, take the following precautions:

- Do not use non-rechargeable batteries in your Mag-Lite® Rechargeable Flashlight System™
- Use only a MAG® rechargeable battery pack (Model No. ARXX075) with this flashlight.
- Always install the battery pack with the positive (+) end facing the head end of the flashlight and the negative (-) end facing the tailcap end of the flashlight.
- When storing your flashlight for long periods of time, remove the battery pack and store it separately.
- Carefully follow the steps listed under “Inspection and Maintenance” in this manual.
- This product is not recommended for use by children.

The safety instructions have been classified according to the seriousness of the risk, as follows:

DANGER:

“Danger” indicates the existence of a hazard that could result in death or catastrophic bodily injury, if the safety instruction is not observed.

WARNING:

“Warning” indicates the existence of a hazard that could result in serious bodily injury, if the safety instruction is not observed.

CAUTION:

“Caution” indicates the existence of a hazard that could result in minor bodily injury or property damage, if the safety instruction is not observed.

NOTICE:

“Notice” contains general information that relates to the safe operation of the flashlight system.

PROTECTION OF CHILDREN:

- Never allow children to play with your flashlight, as they might hurt themselves or others.
- Always keep all accessories and components out of the reach of small children. Small parts, in particular, might present a choking hazard to children.
- Do not allow children to handle or operate this flashlight.

BATTERY DISPOSAL:

- Never discard a used battery pack with ordinary solid wastes, since it contains toxic substances.
- Always dispose of a used battery pack in accordance with prevailing community regulations relating to the disposal of household toxic wastes.
- Always cover the metal terminals with insulating tape first, to prevent accidental short-circuiting whenever transporting outside of flashlight.
- The sealed battery stick contains nickel-cadmium and must be recycled or disposed of properly. Contact your local county solid waste authority for proper recycling or disposal information.
- Mag Instrument, Inc. is a proud participant in the RBRC (Rechargeable Battery Recycling Corporation). By recycling NiCad rechargeable batteries, you are helping to keep NiCad batteries out of the solid waste stream. When you throw away a NiCad battery, it eventually ends up in a landfill or municipal incinerator. By recycling your used NiCad batteries through Mag Instrument’s Battery Recycling Program, you are helping to create a cleaner and safer environment for generations to come. For more information about the RBRC visit www.rbrc.com

DANGER:

- To prevent serious damage to eyesight, never look into flashlight when light is on. Do not shine light into the face of someone else.
- Never attempt to disassemble or repair the AC adapter or charging cradle as exposure to electric shock hazards may result. Always contact a Mag Authorized Warranty Service Center, if repair or replacement is required.
- Never alter the AC cord or plug on your AC adapter or charging cradle. If the plug will not fit into the available outlet, have a proper outlet installed by a qualified electrician. Improper connection can result in the risk of electric shock.

WARNING:

- Never attempt to disassemble the flashlight or any of its components and or accessories. If service or repair is required, return the unit to a Mag Authorized Warranty Service Center.
- Always use genuine Mag-Lite® replacement parts and accessories when operating this flashlight system, as the use of incompatible auxiliary equipment could result in fire, electric shock or other bodily injury. Never connect this flashlight to any unauthorized or incompatible auxiliary product that has not been expressly approved by Mag Instrument, Inc. The use of

unauthorized accessories will also void your warranty.

- Never store or transport flammable liquids, gases or explosive materials in the same compartment as the flashlight or any of its accessories, as possible sparking in the equipment could ignite a fire or explosion.
- Always secure this flashlight in its charging cradle, when it is not in use. Never place the flashlight on the passenger seat or anyplace else in the car where it can become a projectile during a collision or sudden stop.
- Never short-circuit a battery pack by either accidentally or intentionally bringing the terminals in contact with another metal object. That could result in burns, other bodily injury or a fire, and could also damage the battery pack.
- Never expose the terminals of the battery pack to any other metal object. Always wrap it or place it in a plastic bag, whenever transporting it.
- Never heat and never attempt to disassemble the battery pack, as that could cause leakage of the caustic electrolyte. If the battery is accidentally broken, avoid skin contact with the contents. In the event of skin contact, wash the affected area immediately and obtain prompt medical attention.
- Never attempt to dispose of a battery pack by throwing it into a fire. That can cause the battery pack to explode.
- In order to avoid any risk of bodily injury or property damage never attempt to use an unauthorized battery pack with your flashlight.
- Never allow any liquids or water to spill on the AC adapter or charging cradle. There is a risk of fire or electric shock.
- Always use the authorized Mag-Lite® AC adapter and charging cradle to avoid any risk of fire or damage to your flashlight or battery. Bodily injury or property damage may occur as a result of the use of an unauthorized and incompatible AC adapter or charger.
- Never use an AC adapter or charging cradle if it has a damaged or worn power cord or plug. The use of damaged or worn power cords or plugs could result in electric shock, burns or fire. Contact a Mag authorized warranty service center immediately to obtain a suitable replacement.
- Do not attempt to charge this flashlight if cords, adapters, battery, bulb or any part of the flashlight or charger is damaged or corroded.
- Always unplug the AC adapter or charging cradle from the power source before attempting any cleaning in order to avoid the risk of electric shock.

CAUTION:

- Always confirm that the power cord is located so that it will not be stepped on, tripped over, or otherwise subjected to damage or stress.
- Never place heavy objects on a power cord, as this could result in damage to the cord.
- Never bend or twist a power cord, and never pull on a power cord in an attempt to remove an AC adapter or accessory plug from a socket. Always grasp the AC adapter or the accessory

plug directly when unplugging the device in order to avoid damaging the cord.

- Always disconnect the AC adapter or charging cradle from the power source when it is not in use.

⚠ NOTICE:

- Do not use this product for other than its intended use.
- Do not use an outdoor AC outlet to recharge battery.
- Never expose this flashlight system to high temperatures, such as those found near a heater or in a closed car parked in the sun. This can cause heat-damage to the plastic parts, the electronic components and the battery.
- Dropping this flashlight or subjecting it to violent impact or shock can cause mechanical damage.
- Do not charge or operate in close proximity of combustible or flammable materials.
- Do not charge battery in gas tight enclosures.
- Never store this flashlight in cold areas. When the flashlight warms up (to its normal operating temperature), moisture can form inside the flashlight, which may damage the flashlight's electronic components.
- Never paint this flashlight. This can clog the moving parts.
- System 1, 3, and 6: The AC Adapter requires the use of a standard 120 V AC power source for its operation. Or, 12 V DC with the optional Cigarette Lighter Adapter
- System 4, and 5: The AC Adapter requires the use of a standard 230 V AC power source for its operation. Or, 12 V DC with the optional Cigarette Lighter Adapter
- Discontinue use immediately should you notice any changes in the battery, such as discoloration or malformation
- Recharge the Battery at room temperatures: 68°f to 86°f (20°c to 30°c) to prevent hazardous gas venting from the battery cells and potentially reduced battery capacity
- After extended and/or high temperature storage, all Ni-Cd batteries may only accept a partial charge even with full recharging time. The capacity returns to normal after 1 to 3 charge/discharge cycles.



MAGLITE®

Rechargeable System (NiCad)

Contents

Getting Started.....	4
The Flashlight.....	5
The Charging Cradle.....	6
Installation.....	8
The Battery.....	9
Operation - <i>Getting the Most out of Your Mag-Lite® Rechargeable Flashlight System™</i>	10
Frequently Asked Questions.....	10
Changing the Lamp.....	11
Troubleshooting, Specifications.....	12
Warranty.....	13
Inspection and Maintenance.....	13
Other Mag Products and Accessories.....	62
Nederlands	14
Français	26
Deutsch	38
Español	50

Getting Started

Congratulations

You have just made a life-long investment in one of the most highly-advanced precision instruments in illumination technology.

The Mag-Lite® Rechargeable Flashlight System™ was formulated on precision and quality — derived from “Mag’s” many years of experience in the precise world of fine machine tools, our flashlights quickly became recognized for form and function and most importantly, to you the consumer, quality and dependability.

Taking a few moments to read this manual and familiarizing yourself with the Mag-Lite® Rechargeable Flashlight System™ will help to insure years of superior service and satisfaction. To help acquaint yourself with your new flashlight this manual is composed of eight sections: **Section 1)** The Flashlight, **Section 2)** The Charging Cradle, **Section 3)** Installation, **Section 4)** The Battery, **Section 5)** Operation - *Getting the Most out of Your Mag-Lite® Rechargeable Flashlight System™*, **Section 6)** Changing the Lamp, **Section 7)** Trouble shooting, Specifications, Accessories **Section 8)** Warranty Information.

CHECK MARK SHOWS COMPONENT INCLUDED IN EACH SYSTEM							
ITEM SYSTEM NO.	1	2	3	4	5	6	7
NO. MODEL NO.	RX1019	RX2019	RX3019	RX4019	RX5019	RX6019	RX7019
1 Rechargeable Flashlight	✓	✓	✓	✓	✓	✓	✓
2 Charging Cradle	✓	✓	✓	✓	✓	✓	✓
3 Rechargeable Battery (NiCad)	✓	✓	✓	✓	✓	✓	✓
4 Mounting Brackets (x2)	✓	✓	✓	✓	✓	✓	✓
5 120 Volt Converter (US)	✓		✓			✓	
6 12 Volt Adapter (Automobile)	✓	✓		✓			
7 230 Volt Converter (Euro)				✓	✓		
8 12 Volt Straight Wire (Automobile)						✓	✓

What this package contains:

(see chart for your system, 1-7)

Great care has been taken in the design, manufacturing and packaging of your Mag-Lite® Rechargeable Flashlight System™.

- | | |
|---------------------------------|---------------------------------------|
| 1. Flashlight | 5. 120 Volt Converter (US) |
| 2. Charging Cradle | 6. 12 Volt Adapter (Automobile) |
| 3. Rechargeable Battery (NiCad) | 7. 230 Volt Converter (Euro) |
| 4. Mounting Brackets (x2) | 8. 12 Volt Straight Wire (Automobile) |

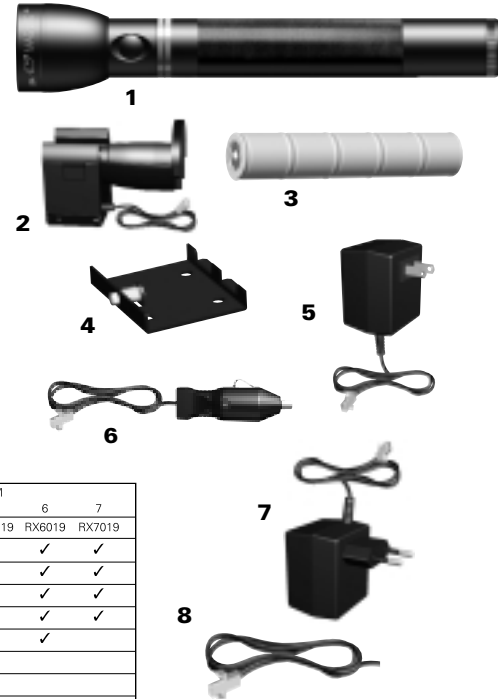

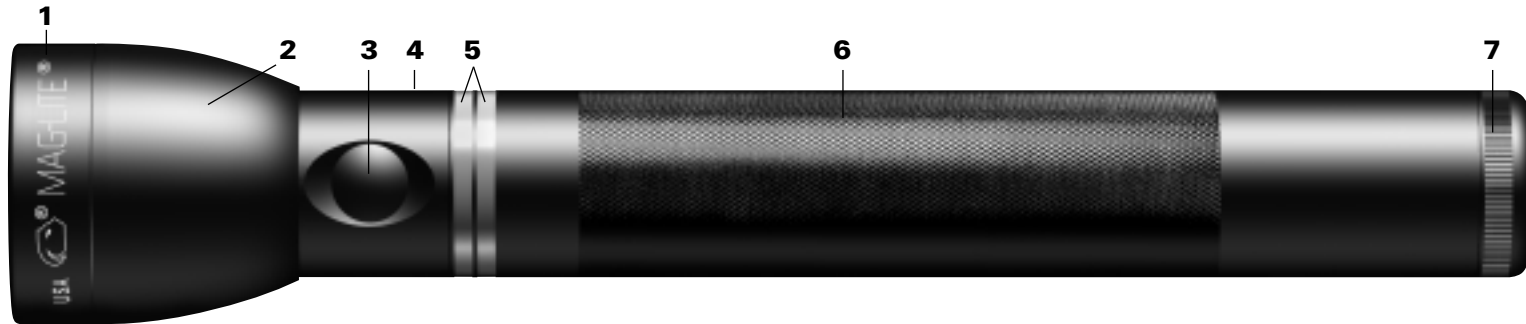

1. Face Cap Assembly (lens and reflector)

The Face Cap Assembly is removable for replacement of lamp only. The reflector assembly is factory sealed and should not be removed from face cap (Fig. 1). **Lens:** The high-efficiency tempered glass lens on the Mag-Lite® Rechargeable Flashlight System™ is an integral part of the optical system. It is precision cut, ground and tempered for its application. Besides its high transmittance of light, the lens has greater resistance to temperature, acids and solvents. **Reflector:** Highly-polished, scientifically-designed, metallic reflector withstands extreme temperatures.

Note: The heat tempered lens can suffer breakage if misused. 1. DO NOT USE AS AN IMPACT TOOL! 2. Do not operate flashlight with the face cap off and the lamp on and exposed. Personal injury or damage to heat sensitive materials may result, e.g. plastics, rubber, cloth fabrics, etc.

2. Head The head is not removable; any attempt to do so will only damage its function. The head can be lowered to the Charging Ring Module for replacement of lamp (see page 11). **Focusing Beam:** patented cam-action focusing mechanism by Mag Instrument has been further enhanced (Fig. 2) to allow for continuous rotation of the head.

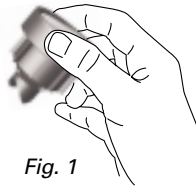

Fig. 1

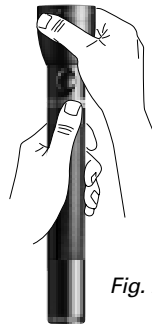

Fig. 2

3. Switch A Mag Instrument advanced concept that is patented and already considered one of the best in its field. The switch is a sealed, rotating, self-cleaning unit and its button is designed to be cleanly flush to the barrel.

4. Serial Number Permanently stamped serial number for registration and identification.

5. Charging Ring Module This unique circular ring concept allows for a positive contact of 360°. No matter how you place the flashlight in the Charging Cradle ... it's on. This module is factory sealed; no attempt should be made to disassemble this module.

6. Durable Finish The barrel, head assembly, Charging Ring Module and tail cap are of Hard Type III anodized aircraft aluminum inside and out. With minimum care, your flashlight will maintain its rich black appearance indefinitely. (Direct constant exposure to sunlight will fade any color.) The barrel features the ultimate in diamond knurl design.

7. Spare Lamp in Tail Cap For your convenience a spare halogen bulb resides in the tail cap should your lamp ever need replacing.

Section 2 *The Charging Cradle*

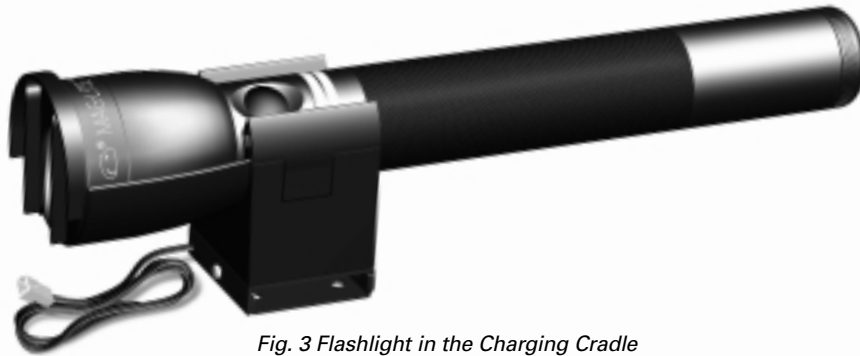

Fig. 3 Flashlight in the Charging Cradle

6

If you have received your system with the flashlight mounted in the Charging Cradle (Fig. 3) the first thing to do is to remove the flashlight.

Note A: Since the Charging Cradle was designed to hold the flashlight securely you'll find that before the unit is mounted, considerable pressure is necessary to release the flashlight from the clamps. It is really quite easy: **1.** Holding the Charging Cradle firmly in one hand (Fig. 4), grasp the flashlight with the other. **2.** A firm downward pressure with the thumb on one clamp while pulling up on the barrel with the other four fingers will quickly snap it free.

Note B: By its unique design, returning the flashlight to the Charging Cradle takes less than 1/10 the force of removing it. Little more than its own weight is sufficient. And, once it is mounted to a wall or in a vehicle, you'll find that the designed leverage takes no effort at all.



Fig. 4

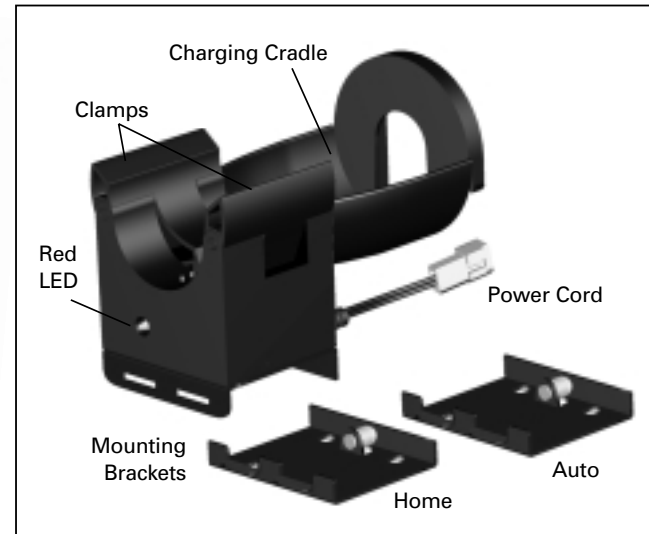

Charging Cradle

Constructed of super-strong, resilient material, this Charging Cradle unit has many features. Solid-state electronics provide a constant charge rate; from an input from 12–14 volts (automotive installations) or 120 volts AC, when used with a converter, in-house. A unique clamp design holds the flashlight securely in a vehicle under rough conditions and its quick release mounting bracket allows easy removal of system.

Note: All electrical components are designed for 12–14 volts DC circuits. **DO NOT USE IN 24-VOLT DC CIRCUITS.** Doing so creates excessive heat and may result in a fire or melted components.

The Charging Cradle's Quick Release Mounting Bracket

Turning the Charging Cradle upside down, you will see a release pin on the same side as the power cord (Fig. 5). Depressing this pin with the index finger or (closed) ballpoint pen will release the mounting bracket for installation. When locating and mounting the bracket, be sure that the release pin (Fig. 6) faces in the same direction as you want the head of the flashlight to be. **Note:** Because of the innumerable places that can be chosen for mounting, there are no screws or fasteners supplied. Be sure to use fasteners that give maximum holding power for repeated use.

Two mounting brackets are included for location versatility.

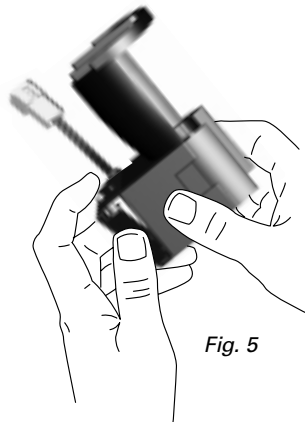

Fig. 5

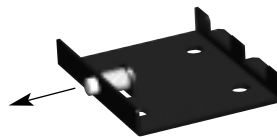

Fig. 6

Charging Cradle Clamp Arms

Note the difference, in the following illustrations, between the "clamps open" position (Fig. 7) and the "clamps closed" position (Fig. 8). Sometimes one or both clamps (they work independently) will be inadvertently pushed to the closed position, making it very difficult to return the flashlight to the recharger/cradle. If this happens, simply take thumb and forefinger and snap it back to the open position (Fig. 9).



Fig. 7
Clamps Open



Fig. 8
Clamps Closed

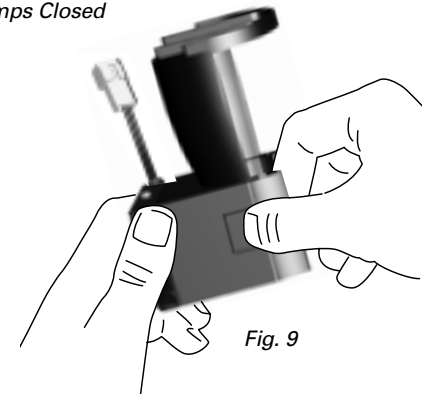

Fig. 9

A Typical Installation

1. Locate and mount the mounting bracket (Fig. 10) using appropriate screw and anchors for that location and material.
2. With flashlight out of the Charging Cradle, engage the two prongs of mounting bracket with matching slots at base of the Charging Cradle ... roll it forward and over the spring-loaded pin lock (Fig. 11). Make sure it has fully engaged the pin. Removal of the Charging Cradle is achieved by simply depressing this pin with the index finger or (closed) ballpoint pen and reversing the procedure.
3. Plug the Charging Cradle's 2-pronged, vibration-resistant, friction-lock connector into the matching end of the DC power cord or AC converter.

Note: When disconnecting plugs, never pull on wires. The Mag-Lite® Rechargeable Flashlight System™ detachable mounting bracket allows the Charging Cradle to be removed from the vehicle, taken to the home, station house or office for continued charging. One extra mounting bracket is included for mounting in two different locations.

8

CAUTION: Make sure wires cannot be pinched. If wire is pinched it can cause immediate short and wires will get hot and melt plastic.

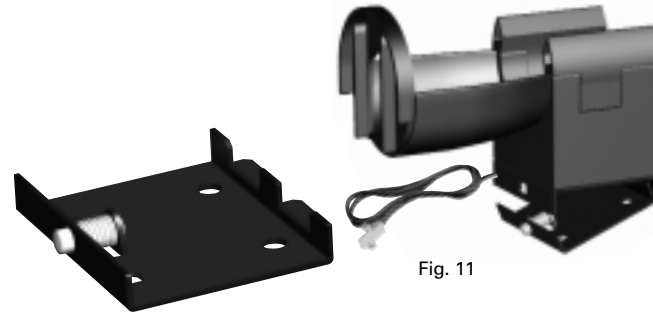
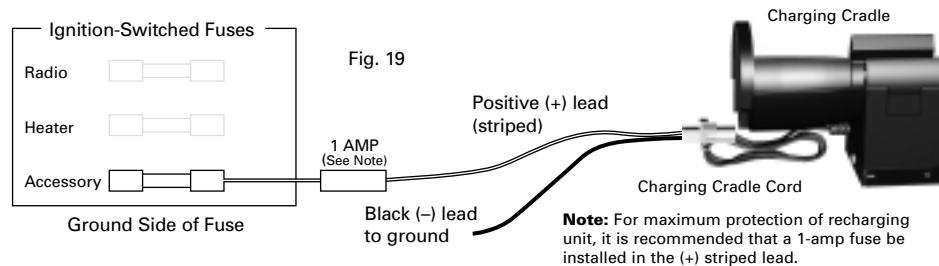

Fig. 10

Fig. 11

Direct Wire-Vehicle Installation 12-14 Volt Only (Not for 24-Volt Systems)

A 4' power accessory cord is available to facilitate the direct-wiring of the rechargeable system (Fig. 19). Mag Instrument recommends using only an ignition-switched (fused) circuit, and preferably the lowest output available (5 amps or less). This is most often the radio or accessory fuse. The striped (positive) lead is connected to the fuse output, and the unmarked (negative) ground wire should be attached to a metal part of the chassis, which serves as a battery ground return.



Your Battery's First Charge Is Important!

To assure the freshness of your battery and to avoid any operational problems in shipping, it has been packaged in an UNCHARGED state. For optimum operation of your flashlight, it should be charged a full 16 hours ... before using for the first time.

Battery Installation

If the battery was shipped outside of the flashlight: After you have removed the flashlight from the Charging Cradle unscrew the tail cap (Fig. 12) and insert battery pack (Fig. 13) into the barrel. The positive (+) end—this is the end with a button—goes into the barrel first. Now screw on the tail cap and make sure it's tight. **NOTE: Large end of the battery spring must be snapped into the tailcap.**

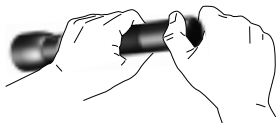
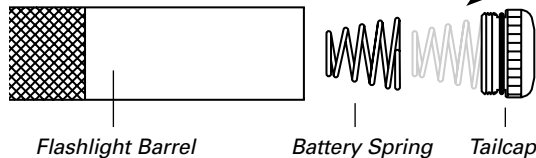

Fig. 12



Fig. 13



If the battery was shipped inside the flashlight: Except for the complete Mag-Lite® Rechargeable Flashlight System™ kits, some systems will be already loaded in the barrel. In this case, you will note that the tail cap is not completely tightened. This is done at the factory as a safety precaution, to keep the flashlight inoperable during shipment. You must firmly tighten the tail cap (Fig. 12) to assure positive electrical contact. Neither the flashlight nor the Charging Cradle will operate if this is neglected.

First Charge Procedure

Do Not Have Flashlight Switch in "On" Position While Charging

1. Make sure tail cap is tight **2.** Place the flashlight into the Charging Cradle. **3.** Connect the Charging Cradle power cord into the AC converter or DC cord, and **4.** Plug into power source. **5.** Make sure LED light is on. See "Helpful Hints" to make sure the flashlight is charging properly.

Helpful Hints

Your battery is presently discharged. There may not be enough power to light the lamp. To be absolutely sure flashlight switch is off, use this simple test. **1.** Remove battery from flashlight. **2.** Plug the Charging Cradle into a power source. **3.** Place flashlight barrel (empty) into the Charging Cradle... the Charging Cradle LED (red) will be "on" if switch is on ... "off" if switch is off. **4.** If LED is on, press switch. **5.** Reload battery and tighten tail cap ... LED will return to "on" indication. Continue charging.

⚠WARNING: Do not "short" or "ground out" battery pack to "deeply discharge". Doing so is hazardous and will damage the battery pack.

Switch Operation

The flashlight utilizes a self-cleaning 3-position rotary switch; **on**, **off**, and **signal** (manual, momentary on-off). When the flashlight is **off** depressing the switch until it clicks **on** will provide a sustained beam. Depressing fully again will turn it **off**. The **signal** feature can be used by partially depressing the switch until the beam comes **on** and releasing it for **off**.

△NOTICE: To avoid deeply discharging the rechargeable NiCad battery, always turn the flashlight off when the flashlight beam starts to dim or turn yellow. A dim or yellow beam is an indication that the battery needs to be fully recharged. Always recharge the battery for 16 hours to obtain a full charge.

Spot-to-Flood Beam

- 10 Patented “continuous cam-action” allows you to change the flashlight from a spot-focus to a flood beam. Operates with a simple quarter turn of the flashlight head assembly.

Frequently Asked Questions

Q. How long can I leave the flashlight in the Charging Cradle (on charge) without using?

A. Indefinitely ... but beyond 30 days of non-use, no purpose is served. When not in use, good practice would dictate disconnecting the units power plug. Battery self-discharge would be less than 1% per day.

Q. How long can I expect my lamp (bulb) to last?

A. 50–60* hours, not counting mechanical shock abuse. Lamps become more fragile toward end of lamp life.

Q. Why is there a dark spot in the beam when light is adjusted to flood?

A. The Mag-Lite® Rechargeable Flashlight System™ reflector is designed for the best spot possible. What you see in the flood position of the reflector is a redistribution of the light to the widest part of the reflector.

Q. Can I touch the glass of the lamp with hands, and if so, will the oils cause lamp damage?

A. You can touch the glass when it's off/cool without fear of lamp damage. However, it is always good practice to wipe lamp with a soft cloth or tissue after handling.

Q. If dust occurs inside my reflector, how do I clean it without damage to the reflector?

A. Use a camel hair brush lightly or blow with dry air. Use the same care that you would give a precision camera lens.

Q. Will the lens break?

A. Yes; however, due to the type of composition and seal, it is much stronger than a regular glass lens.

Q. How do I get a fingerprint off my reflector?

A. Use a camera lens cleaner and a lint-free cloth.

Q. If the small red light in the Charging Cradle does not light, how do I know whether it's the flashlight or the Charging Cradle that's at fault?

A. With the Charging Cradle plugged in and the flashlight not in the Charging Cradle, place a coin, paper clip or metal object across the pins in the Charging Cradle. If the Charging Cradle is OK, the red light will go on. Otherwise, the fault is in the flashlight.

Optimizing Spot Beam with the Light off

To obtain the best “spot pattern” and beam focus it is important to center the bulb in the bottom opening in the parabolic reflector. The bulb has two pins which allow for this adjustment. After inserting the bulb in the receptacle, apply a slight pressure on the bulb with your thumb and index finger to obtain alignment (Fig. 14). Place the reflector over the bulb and look through the clear lens to visually inspect for proper centering. Re-adjust as required. Gently wipe bulb surface with a clean, soft cloth to remove fingerprints.

△WARNING: Do not look at lamp when flashlight is on. Do not touch the lamp until it has cooled for at least two minutes.



Fig. 14



Changing the Lamp

The Halogen Lamp

For the ultimate in flashlight power as well as practicality, the Mag-Lite® Rechargeable Flashlight System™ features a halogen, tungsten filament, pin-type replaceable lamp (bulb). Though small in size, its specifications are large: 6 volts, 8.4 watts and a rating of 50 hours.*

CAUTION: This bulb is pressurized and CAN SHATTER OR EXPLODE, causing PERSONAL INJURY. Wear protective eyeglasses and clothing when handling; never scratch bulb's glass envelope; never splash bulb with liquids. Bulb BURNS VERY HOT and CAN CAUSE BURN INJURY OR HEAT OR FIRE DAMAGE. Remove battery pack and let bulb cool at least two minutes before handling; avoid operating near materials that are flammable or prone to heat or drying damage. Dispose of lamp with care.

Removing the Lamp

1. Holding the largest part of the flashlight's head, unscrew the face cap/reflector assembly. It will come out with the face cap. This is factory assembled and should not be taken apart (Fig. 15).

2. Holding the barrel in one hand (Fig. 16), gently lower the head until it touches the Charging Ring Module (two silver rings). This reveals the lamp for replacement.

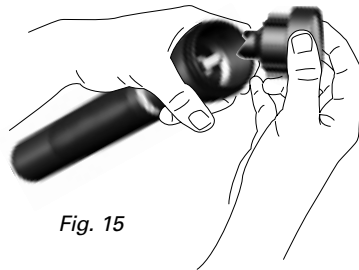

Fig. 15



Fig. 16

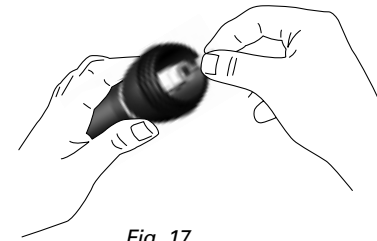

Fig. 17

3. Grasp the lamp firmly (Fig. 17) with thumb and forefinger. Pull straight up until lamp's pins are clear of receptacle. Do not dispose of old lamp in fire or trash compactor.

CAUTION: Lamp is pin-type; do not apply excessive pressure.

4. The New Lamp

Line up the new lamp's pins (Fig. 17) with the 2 holes in receptacle and apply a straight downward pressure.

Note: The receptacle is spring-loaded and the entire unit (receptacle) will move down about 1/4 inch. When the glass of the lamp touches the receptacle, release pressure and let go. Gently wipe bulb surface with a clean, soft cloth to remove fingerprints.

5. Raise the head of the light (Fig. 15) to its full up position. Reinsert face cap and reflector assembly and screw on tightly.

*Lamp life may vary.

If you have questions or need assistance, please call our warranty/repair facility at 01 (909) 947-1006.

Problem**Cause/Correction****Flashlight:**

Does not light

1. Tighten tail cap – make sure unplated area of tail cap and barrel are clean.
2. Check if battery is installed ... see page 9.
3. Check if battery is installed with (+) positive end toward head of flashlight.
4. Make sure large end of battery spring is snapped into tailcap.

Battery charged?

1. Check battery charge: Place flashlight in recharger/cradle. Make sure LED lights up with flashlight switch off (see page 9). Charge for 15 minutes ... check for light. If it lights (even momentarily) charge it, if not, replace it (battery).

Switch sticks

Works intermittently

1. Return flashlight to Mag Instrument (see warranty).
1. Check for damage to battery casing.
2. Foreign particles inside barrel.
3. Lamp not seated properly.

Poor or no spot

1. Lamp needs centering (see page 10).
2. Damaged lamp (filament off-center) — replace.

Recharger/Cradle:

LED indicator does not light when flashlight switch is in off position.

1. Tighten tail cap.
2. Check plug connection to converter.
3. Check plug to power source.
4. Check Switch-off procedure (see page 9).
5. Make sure large end of battery spring is snapped into tailcap.

Inspection and Maintenance

Battery Pack – See Warnings Section for more information. Periodically (approximately every month) remove the battery pack from the flashlight and visually inspect for signs of gas or chemical leakage. Indications of leakage are discoloration of the plastic sleeve or white fuzzy material near the top (positive side button) of each cell. Another indication would be a bulging deformation of the bottom (negative flat end) of the cell can. If these signs are observed the battery pack should be removed from service to prevent chemical damage to the inside of the flashlight. **See One Year Battery Pack Warranty for more information concerning warranty coverage.**

Fully Charged Battery Storage – If you do not use your flashlight for long periods of time (four months or more) we suggest you remove the battery pack from the flashlight to prevent chemical damage (acid leaks). **Electrical Contacts** – The bare (bright) metal surfaces between the tailcap and barrel must be cleaned periodically to ensure a good electrical contact. Also keep the tailcap spring clean. **O-ring Seals and Screw Threads** – To keep seals from drying out and the threads operating smoothly, apply several drops of clean petroleum oil or jelly to these surfaces two or three times a year. **Anodized Exterior Finish** – The protective finish on the flashlight is very durable; however, constant exposure to sunlight, water, chemicals, gases, etc., will dull, discolor and eventually destroy the protective finish. Care should be taken to avoid any harsh environment.

Flashlight

- Tempered aluminum alloy external components
- Finish: hard, type III, aircraft anodized (inside and out)
- Length: 12-19/32" (319.79 mm)
- Weight, with battery pack: 32 oz. (907.18 grams)
- Weight, without battery pack: 18 oz. (510.29 grams)
- Head diameter: 2-5/16" (58.72 mm)
- Barrel diameter: 1-9/16" (39.67 mm)
- Permanently stamped serial number for registration and identification
- O-ring sealed throughout
- Corrosion resistant, rotating (self-cleaning) push-button switch
- High intensity halogen lamp (50* hour rating) Easy replaceable lamp
- 40,000 peak beam candlepower
- 6.00 Volt Ni-Cad Battery Pack Rechargeable up to 1000 times
- High-Quality Tempered Glass Lens
- Highly-polished, scientifically-designed, metallic reflector withstands extreme temperatures
- Diamond knurl design
- Cam-action adjustable beam from spot to flood with 1/4 turn of head
- Corrosion resistant metal springs throughout
- Spare Halogen lamp included in tailcap
- Up to 2 hours* flashlight on-time per charge
- Charging Cradle
 - Universal: Accepts 12–14 volts DC (not for use with 24-volt systems)

- Constant current solid-state integrated circuit regulator
- Charge rate: 230 mA continuous
- 360° positive charge contact allows charging in any position
- Reverse voltage protected (batteries in backwards) Input and Output
- Red light emitting diode (LED) charge indicator
- Mounts in any position
- Includes (2) detachable mounting bracket

Converter

- Input 120 volts AC 60Hz
- Output 12–14 volts DC
- Double insulated

12

12 Volt Adapter (Automobile)

Plug the DC power cord's adapter into the 12–14 volt cigarette lighter receptacle of the vehicle. DO NOT leave adapter plugged in for any extended period while the engine is "off" to avoid draining vehicle battery.

**230-Volt Converter**

After mounting the Charging Cradle in a proper location, plug the special matching electrical connectors together at the wire ends of the Cradle and Converter. Plug the Converter into an appropriate 230 volt wall receptacle.



Note: Total usable wire length is 8 feet.

*Due to improved lamp, first announced early 2002. Candlepower and battery on-time can vary due to manufacturing variations in lamps and batteries. (PBC) Peak Beam Candlepower. Lamp life may vary.

TEN YEAR LIMITED WARRANTY ON FLASHLIGHT SYSTEM / ONE YEAR LIMITED WARRANTY ON BATTERY PACK

MAG INSTRUMENT, INC. ("Mag") warrants to the original owner that this MAG-LITE® RECHARGEABLE FLASHLIGHT SYSTEM™ (the "SYSTEM") is free from defects in parts and workmanship. As to the flashlight and other components of the SYSTEM, except the rechargeable NiCad battery supplied herewith, this warranty lasts for ten years from the date of first retail purchase. As to the NiCad battery, this warranty lasts for one year from date of purchase. Registration is not required for warranty coverage. Mag or an authorized Mag Warranty Service Center will repair the flashlight or other SYSTEM component or, at its option, replace a defective flashlight or other SYSTEM component free of charge. This warranty is in lieu of all other warranties and conditions, express or implied.

Exclusions: This warranty does not cover lamp burnout or damage to or failure of the SYSTEM or any component thereof due to alteration, product misuse, lack of maintenance, or leakage of a NiCad battery more than one year after date of purchase. (Product misuse includes, but is not limited to, installing any non-rechargeable battery or any rechargeable battery pack other than a Mag® battery pack or its technical equivalent.)

Mag disclaims any responsibility for incidental or consequential damages. Some jurisdictions in Canada and the United States do not allow exclusion or limitation of implied warranties, incidental or consequential damages and/or limitations on transferability, so the above limitations and exclusions may not apply to you.

How and when to make a warranty claim: Before returning the flashlight or other system component for service, be sure you have followed the steps outlined in the **Troubleshooting Guide section** of your MAG-LITE® RECHARGEABLE FLASHLIGHT SYSTEM™ Owner's Manual. If you have followed all of these steps and the flashlight or other SYSTEM component fails to operate properly, proceed as follows: 1. In case of bulb burnout, or in case of NiCad rechargeable battery failure **more than one year after purchase date**, do not return the flashlight or other system component to Mag but replace the bulb or NiCad battery. You can buy replacement bulbs and NiCad batteries directly from Mag or from most retail outlets where Mag flashlights are sold. 2. For warranty returns: Send the flashlight or other system component (postage or shipping prepaid) to Mag Instrument, 1721 East Locust Street - 51453, Ontario, California, USA 91761-7769, Attention: Warranty/Repair Department, or to an authorized Mag Warranty Service Center. For the location of an authorized Mag Warranty Service Center in your area, consult the retailer where you purchased the flashlight. For your protection and to expedite handling and/or postal claims, we recommend that all returns be insured and sent Certified and/or Return Receipt Requested.

In Canada and the United States this warranty gives you specific legal rights, and you may have other rights which vary from state to state and from province to province. Where any term of this warranty is prohibited by the law of any jurisdiction, such term shall there be null and void, but the remainder of this warranty shall remain in full force and effect. **To register your new Mag® flashlight** visit our website at www.maglite.com. From our home page just go to "Register Your Flashlight."

Owner's Manual • Gebruiksaanwijzing • Guide d'Utilisation Handbuch • Manual del Propietario

Mag-Lite® Rechargeable Flashlight System™

- High capacity rechargeable NiCd battery provides over 1,000 hours of operational life (equivalent to over several hundred alkaline long life batteries).
- Halogen lamp produces one of the brightest, whitest, far-reaching light beams available.
- Patented "continuous" action - quick focusing spot-to-flood beam. Operates with a simple quarter turn of the flashlight head assembly.
- Self-cleaning rotary switch, 3 position, on, off, and signal (manual, momentary on/off)
- Highly polished, metallic reflector, withstands extreme temperatures and delivers superior optical performance.
- High quality tempered glass lens.
- Precision machined high-strength aluminum alloy flashlight case. Hard anodized inside and out for improved corrosion resistance and durability.
- Water resistant seals throughout the flashlight protect all internal components from harsh environmental conditions.
- 360 degree electrical contact rings allow the flashlight to be charged in any position.
- Charging cradle mounts securely in any position within minimal space allocation.
- Individually serial numbered for identification.
- Ten year limited warranty (warranty and owners manual enclosed).
- Recharges on either AC or DC current.

Mag-Lite® Rechargeable zaklantaansysteem™

- Krachtige oplaadbare nikkelcadmiumbatterij met gebruiksduur van meer dan 1000 uur (gelijk aan honderden alkalibatterijen met lange levensduur).
- Halogeenlampje produceert een van de helderste, witste, verst-reikende lichtstralen.
- Geïmplementeerd "doorlopende" roterende voor een snel van nuchter naar spotlicht te focussen per toets. Werkt door een kwartslag van het kopgedeelte.
- Zelfreinigende draaischakelaar met drie standen: aan, uit en signaal (handmatig, kortstondig aan/uit).
- Hoogglanspolijste metalen reflector is bestand tegen extreme temperaturen en levert superieure optische prestatie.
- Lens van kwalitatief hoogstaand voorgespannen glas.
- Precisie vervaardigde zaklantaantrommel van supersterk aluminiumlegering. Hard geanodiseerd binnen- en buitenkant voor betere corrosiebestendigheid en duurzaamheid.
- Waterbestendige afdichtingen overal beschermen alle interne onderdelen van de zaklantaan tegen agressieve omgeving.
- Elektrische contactringen waarmee de zaklantaan in elke positie (360 graden) geladen kan worden.
- Laadvoet kan in elke positie veilig gemonteerd worden en neemt weinig plaats in.
- Elke zaklantaan heeft zijn eigen serienummer ter identificatie.
- Tienjarige beperkte Garantie (ingesloten garantie en gebruikershandleiding)
- Kan op gelijkspanning of op wisselspanning geladen worden.

Système™ de lampe-torche Mag-Lite® Rechargeable

- La batterie au nickel-cadmium de grande capacité présente une durée utile de plus de 1000 heures (l'équivalent de plusieurs centaines de piles alcalines de longue durée).
- L'ampoule à halogène produit l'un des faisceaux blancs les plus brillants et les plus longs.
- Faisceau breveté à réglage rapide par came, de large à faible diffusion, fonctionne par rotation de la tête de lampe sur un quart de tour.
- Interrupteur rotatif automatique à 3 positions: marche (ON), arrêt (OFF) et signal (manuel, momentané)
- Réflecteur métallique de haute précision, supporte des températures extrêmes et offre un rendement optique supérieur.
- Lentille en verre trempé de grande qualité.
- Boîtier de lampe usiné avec précision, en alliage d'aluminium très résistant.
- Intérieur et extérieur anodisés de grande durée, pour une meilleure résistance à la corrosion et pour une plus grande durabilité.
- Scellages d'étanchéité pour protéger tous les composants internes de la lampe-torche contre les intempéries.
- Bagues de contact électrique réglables sur 360 degrés pour permettre de charger la lampe-torche dans n'importe quelle position.
- Boreau de charge montable en toute sécurité dans n'importe quelle position et dans un minimum d'espace.
- Numéros de série individuels pour identifier les modèles de lampes à l'intérieur.
- Garantie limitée de dix ans (voir le guide de l'utilisateur et la garantie à l'intérieur).
- Lampes rechargeables par courant secteur ou courant continu.

Mag-Lite® Rechargeable Taschenlampensystem™

- Hohe Leistungs-NiCd-Akku mit Betriebsstunden (entspricht der Lebensspanne mehrere Hundert Alkalibatterien).
- Halogenglühlampe für einen der hellsten, weißesten und weitreichendsten Lichtstrahlen.
- Patentierte Nockentrieb für rasches Fokussieren des Lichtstrahls von Spot bis Flutlicht. Berührt lediglich eine Viertelumdrehung des Taschenlampenkopfs.
- Selbstreinigender Drehschalter mit drei Stellungen: Ein, Aus und Signal (manuell, momentanes Ein-/Aussschalten)
- Hochpolierter Metallreflektor widersteht extremen Temperaturen und liefert überragende optische Leistung.
- Gehärtete Glaslinse hoher Qualität.
- Präzisionsgefertigtes Taschenlampengehäuse aus massiver Aluminiumlegierung.
- Innen und außen eloxiert für bessere Korrosionsbeständigkeit und Widerstandsfähigkeit.
- Wasser abstoßende Dichtungen überall in der Lampe schützen alle internen Komponenten vor harten Umweltbedingungen.
- 360°-Ladekontaktringe ermöglichen das Laden des Akkus unabhängig von der Taschenlampenposition.
- Lademodul ist in beliebiger Position bei nur geringem Platzbedarf sicher installierbar.
- Individuelle Seriennummer zur einfachen Identifikation.
- Zehn-Jahres-Garantie (Garantie und Gebrauchsanweisung beigelegt).
- Sowohl an Wechselstrom als auch Gleichstrom aufladbar.

Mag-Lite® Rechargeable Flashlight System™ Sistema Mag-Lite®

- Pila de NiCd de alta capacidad que ofrece más de 1000 horas de operación (equivalente a cientos de pilas alcalinas de larga duración).
- La bombilla de halógeno produce uno de los haces de luz más brillantes, más blancos y de más alcance que están disponibles.
- Un haz patentado que enfoca con rapidez de proyección a punto con "acción de levas continua". Opera con un sencillo movimiento de un cuarto del ensamble de la cabeza de la linterna.
- Interruptor rotatorio con auto-limpieza de 3 posiciones: encendido, apagado y señal (encendido y apagado momentáneo manual).
- Reflector metálico altamente pulido que soporta temperaturas extremas y brinda un rendimiento óptico superior.
- Lente de vidrio templado de alta calidad.
- Estuche para la linterna de aleación de aluminio de gran fortaleza y maquinado a precisión. Con aluminio duro anodizado por dentro y por fuera para una mejor resistencia a la corrosión y una mayor duración.
- Sellos resistentes al agua, a todo lo largo de la linterna para proteger todos los componentes internos de condiciones ambientales severas.
- Anillos de contacto eléctrico de 360° que permiten que la linterna se cargue en cualquier posición.
- La base de carga se monta con seguridad en cualquier posición usando un mínimo de espacio.
- Número de serie individual para facilitar la identificación.
- Garantía limitada de diez años (se adjuntan la garantía y el manual de usuario)
- Se recarga ya sea en corriente alterna o directa.



MAG
CORPORATE OFFICE
MAG INSTRUMENT, INC.
1635 South Sacramento Ave.
P.O. Box 5030
Folsom, California U.S.A.
91761-1083

Warranty: 01 (909) 947-1006
fax: 01 (909) 947-5941
e-mail: warranty@magmail.com
Sales & Parts: 01 (909) 947-1006
email: salesdesk@magmail.com
©2004 Mag Instrument, Inc.

www.maglite.com

The distinctive shapes, styles and overall appearances of all Mag® flashlights, and the circumferential inscriptions extending around the heads of all Mag® flashlights are trademarks of Mag Instrument, Inc. The circumferential inscription on the head of every Mag® flashlight that it is an original Mag® flashlight and part of the Mag® family of flashlights. U.S. Trademark Registrations for the shape, style and overall appearance trademarks of Mag® flashlights and for circumferential inscription trademarks of Mag® flashlights include Nos. 1,808,988; 2,074,795; 2,687,693; 2,745,460; 2,765,978 and 2,765,979.

The Mag-Lite® Rechargeable Flashlight System™ is covered by one or more pending patent applications and U.S. Patent Nos. 4,286,311; 4,388,673; 4,527,223; and Des. 263,170; and by foreign patents.